

## 12SB160CL-FR 12Volt 160Ah

### Specifications

Nominal Voltage(V) 12V

#### Nominal Capacity

20 hour rate	(8.01A	to	9.9V)	160.2Ah
10 hour rate	(15.8A	to	9.9V)	158.0Ah
5 hour rate	(26.9A	to	9.6V)	134.5Ah
1 hour rate	(90.0A	to	9.6V)	90.0Ah

Weight Approx. 46.0kg (101.2Lbs.)

Internal Resistance (at 1KHz) Approx. 4 mΩ

Maximum Discharge Current for 5 seconds: 1500A

#### Charging Methods at 25°C(77 °F)

Cycle use:

Charging Voltage	14.4 to 15.0V
<b>Coefficient</b>	<b>-5.0mv/°C/cell</b>
Maximum Charging Current	45A

Standby use:

Float Charging Voltage	13.50 to 13.80 V
<b>Coefficient</b>	<b>-3.0mv/°C/cell</b>

Design Life 12 years

#### Operating Temperature Range

Charge	-15 °C(5 °F)	to	40 °C(104 °F)
Discharge	-15 °C(5 °F)	to	50 °C(122 °F)
Storage	-15 °C(5 °F)	to	40 °C(104 °F)

#### Charge Retention (shelf life) at 20°C(68 °F)

1 month	98%
3 month	94%
6 month	85%

Case Material ABS

(UL94-V0 flame retardant case / cover)

Terminal F16

#### Description of torque value of hard ware for the terminals:

Recommended torque value	<b>M6: 5.39 N-m (55kg-cm)</b>
Maximum allowable torque value	<b>M6: 8.82 N-m (90kg-cm)</b>



### Dimensions mm(inch)

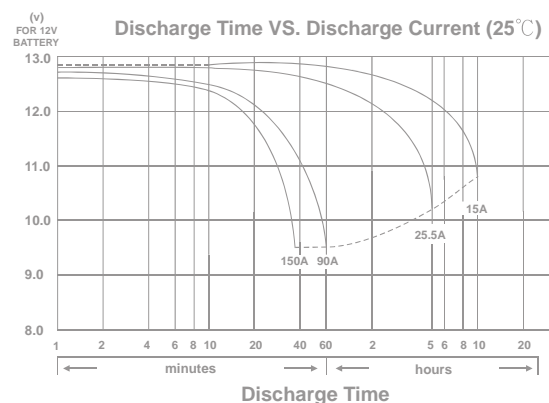
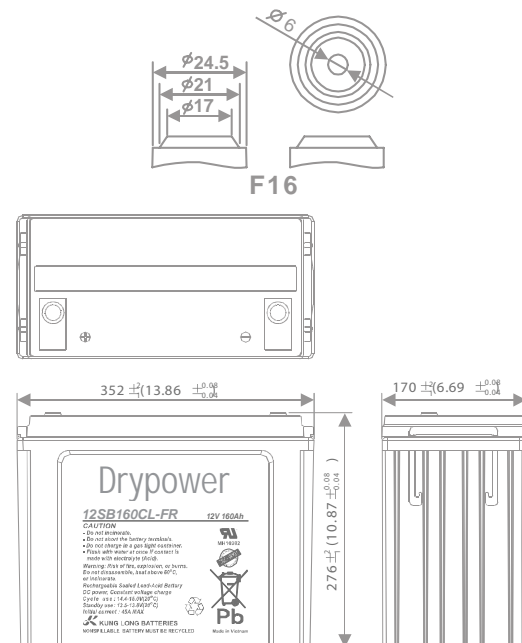

Effect of Temperature on Capacity 25°C(77°F)

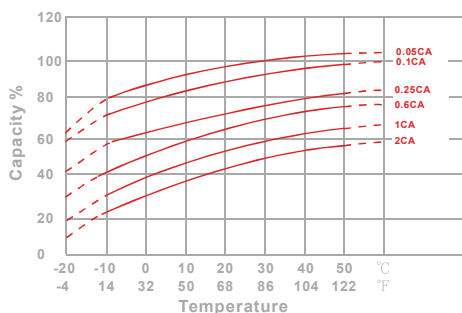

Capacity Retention Characteristic

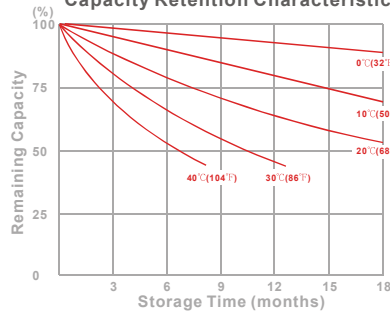

Trickle (or float) Service Life

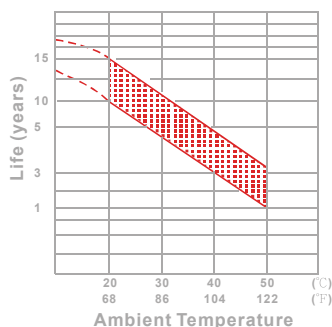

Cycle Service Life

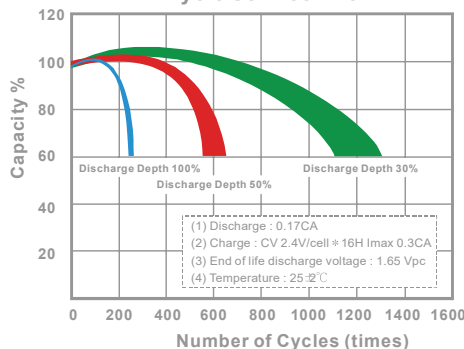

**- PERFORMANCE DATA**

**Discharge Rates in Watts to Various End Voltages at 25°C(77°F)**

End Voltage		1.85V	1.80V	1.75V	1.70V	1.67V	1.65V	1.60V
Time	min							
5	min	3365	3754	4094	4386	4528	4675	4955
10	min	3008	3273	3431	3584	3655	3730	3872
15	min	2656	2810	2921	3029	3079	3131	3223
30	min	1551	1633	1694	1753	1776	1801	1845
60	min	927	981	1019	1045	1053	1062	1076
120	min	503	534	551	565	571	579	591
180	min	412	439	453	466	472	479	488
240	min	336	354	365	373	376	380	386
300	min	289	301	309	316	318	321	325
600	min	171	178	184	189	190	193	196
1200	min	90.6	93.4	95.9	98.1	99.2	100	101

**- Discharge Rates in Amperes to Various End Voltages at 25°C(77°F)**

End Voltage		1.85V	1.80V	1.75V	1.70V	1.67V	1.65V	1.60V
Time	min							
5	min	296	373	417	446	459	472	490
10	min	245	276	303	325	335	346	363
15	min	218	246	265	278	283	289	306
30	min	119	131	141	149	152	155	160
60	min	70.7	79.6	82.8	85.2	86.5	87.9	90.0
120	min	37.5	44.2	45.9	47.1	47.6	48.2	49.1
180	min	32.6	36.2	37.5	38.6	39.1	39.6	40.2
240	min	25.8	28.7	29.8	30.7	31.0	31.3	31.7
300	min	23.9	24.8	25.5	26.1	26.2	26.6	26.9
600	min	14.4	15.0	15.3	15.5	15.6	15.8	15.9
1200	min	7.43	7.62	7.76	7.90	7.95	8.01	8.06

All data on the spec. sheet is an average value:

The tolerance range :  $X < 6\text{min}$  (+15%~-15%),  $6\text{min} \leq X < 10\text{min}$  (+12%~-12%),  $10\text{min} \leq X < 60\text{min}$  (+8%~-8%),  $X \geq 60\text{min}$  (+5%~-5%)